



delivers an impact of
over 500 lbs/sec

Patent Pending



Feed bridging has become a common event in the swine industry as feed rations change due to fluctuating input costs and the use of alternative feed stuffs to lower cost and gain feed efficiency. The "Flow Hammer" is a reliable and affordable solution that easily adapts to most existing feed bins. This patent pending product aids in the prevention of out of feed events in all phases of swine production.

**MINIMIZE FEED
TANK BRIDGING**



FLOW HAMMER

AUTOMATED PRODUCTION SYSTEMS

FLOW HAMMER FEATURES

- Helps minimize feed bridging events to keep feed flowing consistently to animals
- Can be installed on a full or empty bulk feed tank
- Low maintenance and simple installation (no field modifications to the tank are required)

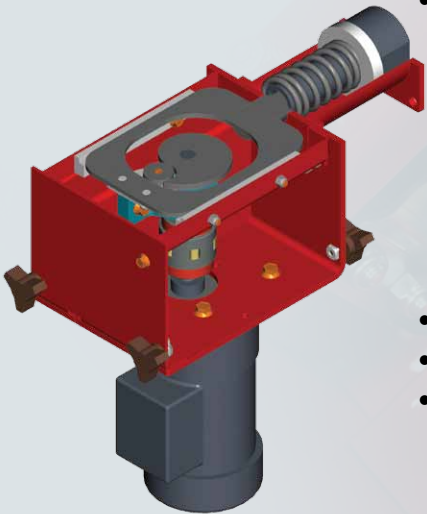

- Control unit has both timed and sensor controlled modes:
 - The timed mode uses an "on" time and a "cycle" time to control the Flow Hammer when the feed system is running.
 - The sensor mode uses a sensing device to detect a feed flow issue and activates the Flow Hammer. Once the event has ended, the Flow Hammer shuts off.
- 240 volt power supply required
- Simple and concise control units, with test mode
- Control unit can be remotely mounted or tank mounted with optional leg bracket



Your Source for Innovative Solutions

While high frequency vibration devices are effective in promoting feed flow, their use can result in loosened hardware and metal fatigue potentially resulting in structural failure. The FLOW HAMMER's low frequency/high impact design promotes feed flow without damaging your feed bin or voiding its warranty.



Patent Pending
Designed and manufactured by AP in the USA



AUTOMATED PRODUCTION SYSTEMS

1004 E. Illinois St. Assumption, IL 62510 USA
217-226-4449 Fax 217-226-3540
Int'l Tel 217-226-4401
Tech Support 712-239-1011



For more information on AP's many products and services, contact your local AP representative or visit us online at:

www.automatedproduction.com