

DROP FEEDERS

AUTOMATED PRODUCTION SYSTEMS



ideally suited
econo/ultra/accu

AP drop feeders provide you with the tools to maintain individual sow condition, decrease stress during feeding, save labor and prevent feed waste. Our feeders are specifically designed to stand up to the harsh environment, daily use and frequent wash downs encountered in modern sow units. Three models are available allowing you to select the features ideally suited to your facilities and application.



ECONO-DROP FEEDERS ▲

Engineered for reliable performance at an affordable price, AP's Econo-Drop features a simple front mounted adjustment, individual slide shut-off, and translucent body for visual confirmation of feed level.



ULTRA-DROP FEEDERS ▲

The Ultra-Drop was designed with producer input to meet the requirements of both gestating and lactating sows. This feeder features convenient one handed adjustment and a balanced design to insure the feeder hangs straight.



ACCU-DROP FEEDERS ▲

Accu-Drop feeders are designed to fill the highly precise requirements of today's diverse production systems. The system can be manually operated or fully automated using an actuator system operated by a programmable timer.



DROP FEEDERS

AUTOMATED PRODUCTION SYSTEMS

ECONO-DROP FEEDERS

Engineered for reliable performance at an affordable price.

Features include:

- Front mounted adjustment.
- Individual slide shut-off.
- Translucent body allows visual confirmation of feed level
- Weighted ball valve securely closes the feeder and insures feed flow when emptying
- All plastic construction with stainless steel hardware



ULTRA-DROP FEEDERS

Designed with producer input to meet the requirements of both gestating and lactating sows.

Features include:

- Convenient knob adjustment
- Balanced design insures that the feeder hangs straight and maintains accuracy
- Individual slide shut-off.
- Translucent body allows visual confirmation of feed level
- Weighted ball valve securely closes the feeder and insures feed flow when emptying
- All plastic construction with stainless steel hardware

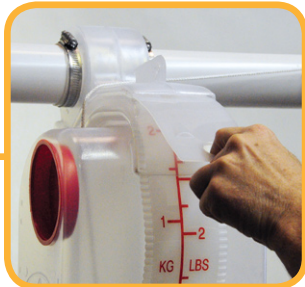
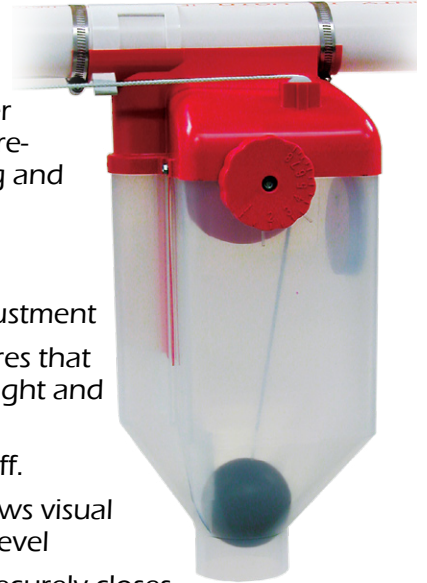

The Econo-Drop feeder is equipped with a conveniently located slide shut-off.



Econo-Drop's front mounted adjustment ranges from 1.5 lbs. to 12 lbs. (.68kg to 5.44 kg).



An easily accessible slide shut-off on the Ultra-Drop cuts feed flow to the feeder.



A half turn of the convenient adjustment knob adjusts the Ultra-Drop feeder from 1 lb. to 8 lbs. (.45kg to 3.63 kg).

DROP FEEDER DIMENSIONS

Model	Front View Width	Overall Height*	Side View Width	Outlet OD	Discharge Off Set	Minimum Capacity**	Maximum Capacity**	Available Models
	A	B	C	D	E			
Econo-Drop	8.5"	20.13"	10.08"	3.31"	2.63"	1.5 lbs. (.68 kg)	12 lbs. (5.44 kg)	ChainDisk, M220, M300 & M350 Flex-Flo™
Ultra-Drop	10.13"	19.23"	10.08"	3.25"	N/A	1 lb. (.45 kg)	8 lbs. (3.63 kg)	ChainDisk, M220 Flex-Flo™
Accu-Drop	9.5"	20.38"***	8.6"	3.16"	N/A	1.5 lbs. (.68 kg)	12 lbs. (5.44 kg)	ChainDisk, M220, M300 & M350 Flex-Flo™

* Overall height for Ultra-Drop and Accu-Drop is stated from the top of the Model 220 Flex-Flo feed line to the bottom of the drop feeder.

** Feeder capacity is approximate and is based on volume which will change as feed density and flowability changes.

*** Adjustment rod on Accu-Drop feeders extends up to 9.5" beyond the bottom of drop feeder at the maximum setting.

ACCU-DROP FEEDERS

Heavy duty construction designed to provide years of durable, reliable performance.

Features include:

- Precision lock-in setting adjustment
- Balanced design insures that the feeder hangs straight and maintains accuracy
- Individual slide shut-off
- Translucent body allows visual confirmation of feed level
- Weighted ball valve securely closes the feeder and insures feed flow when emptying
- All plastic construction with stainless steel hardware

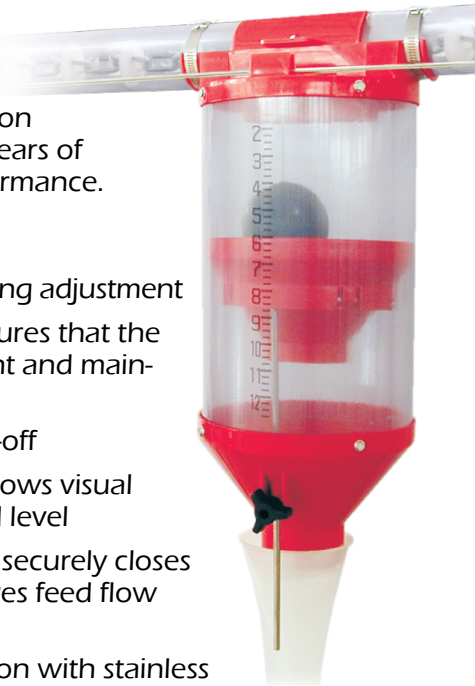

Cut feed access to the Accu-Drop feeder with a simple rotating shut-off located at the top of the feeder.



The Accu-Drop adjuster securely locks the feed setting at 1.5 lbs. to 12 lbs. (.68kg to 5.44 kg).

FEED DELIVERY SYSTEMS AND ACCESSORIES

AP drop feeders are designed to be used with either our Flex-Flo™ or Chain-Disk feed delivery systems which can be adapted to gestation and lactation facilities of any size or design.

A variety of accessories are available to adapt to your equipment, specifications and production practices.



Flex-Flo™ Feed Delivery System



Chain Disk Feed Delivery System



Drop Feeder Control Unit



Adjustable Drop Tube



Automated Actuation System



Manual Actuation Options

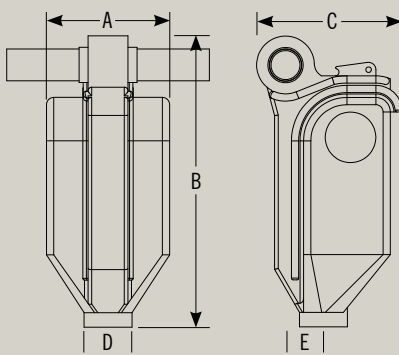

Econo-Drop

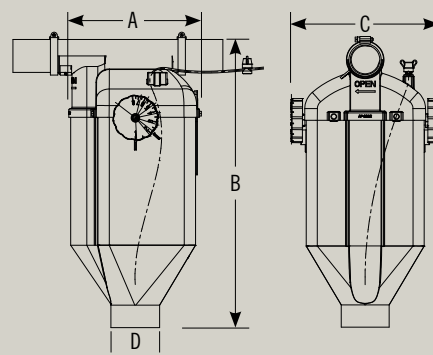

Ultra-Drop

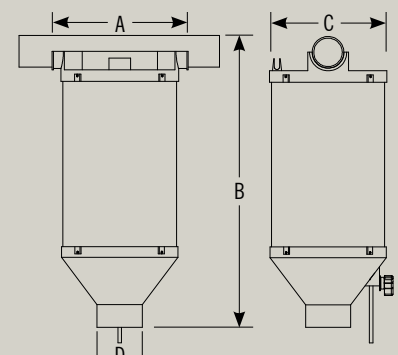

Accu-Drop

DROP FEEDERS

AUTOMATED PRODUCTION SYSTEMS

FARROWING DROP FEEDERS

Eliminate feed carts and reduce the cost of labor associated with hand feeding lactating sows with AP's Farrowing Drop Feeders.

Features include:

- Heavy wall, clear pvc tube and stainless steel valve.
- Capacity markings on the clear feed tube provide an easy indicator of the amount of feed being dropped.
- Sliding band can be moved on the tube to record the amount of feed previously dropped.
- Flexible coupler aids in alignment with the feeder and permit clear access to the head gate.

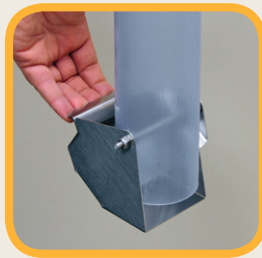

- Spring loaded stainless steel discharge cup snaps securely into the closed position.
- Each feeder is equipped with an individual slide shut-off.

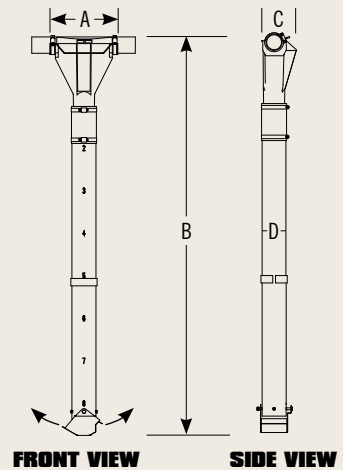

FARROWING DROP FEEDER DIMENSIONS

Model	Front View	Overall	Side View	Tube	Maximum	Available Models
	Width	Height*	Width	OD		
	A	B	C	D		
8 lb.	9.189" 23.3 cm	53.840" 136.8 cm	5.340" 13.6 cm	3.250" 8.3 cm	8 lbs. 3.63 kg.	M236 ChainDisk, M220, M300 Flex-Flo™
12 lb.	9.189" 23.3 cm	52.584" 133.6 cm	5.448" 13.8 cm	4.000" 10.2 cm	12 lbs. 5.44 kg.	M236 ChainDisk, M220, M300 Flex-Flo™

* Overall height is stated from the top of feed line to bottom of drop feeder.

** Feeder capacity is approximate and is based on volume which will change as feed density and flowability changes.



AUTOMATED PRODUCTION SYSTEMS

1004 E. Illinois St. Assumption, IL 62510 USA

217-226-4449 Fax 217-226-3540

Int'l Tel 217-226-4401

Tech Support 712-239-1011

member of
GSI GROUP



5/11 AP-52

For more information on AP's many products and services, contact your local AP representative or visit us online at:

www.automatedproduction.com